

# HUTKIN FOR LEASE

DEVELOPMENT COMPANY *Office / Warehouse*

2505 Metro Boulevard  
Maryland Heights, MO 63043



- **1,080 Square Feet Available**
- **Unit J**
- 1,080 SF
- 100% office finish
- 3 private offices with open space
- Ample parking
- **\$8.25 psf, Modified Gross**

HUTKIN DEVELOPMENT COMPANY  
10829 Olive Boulevard  
Suite 200  
St. Louis, MO 63141

Telephone 314.872.9140  
FAX 314.872.9001

Visit our website:  
[www.hutkin.com](http://www.hutkin.com)

## CONTACT

Bo Keefer  
[bkeefer@hutkin.com](mailto:bkeefer@hutkin.com)  
Cell 314.973.1242

*See site plan and floor plans on reverse*

# HUTKIN FOR LEASE

DEVELOPMENT COMPANY

Office / Warehouse

2505 Metro Boulevard  
Maryland Heights, MO 63043

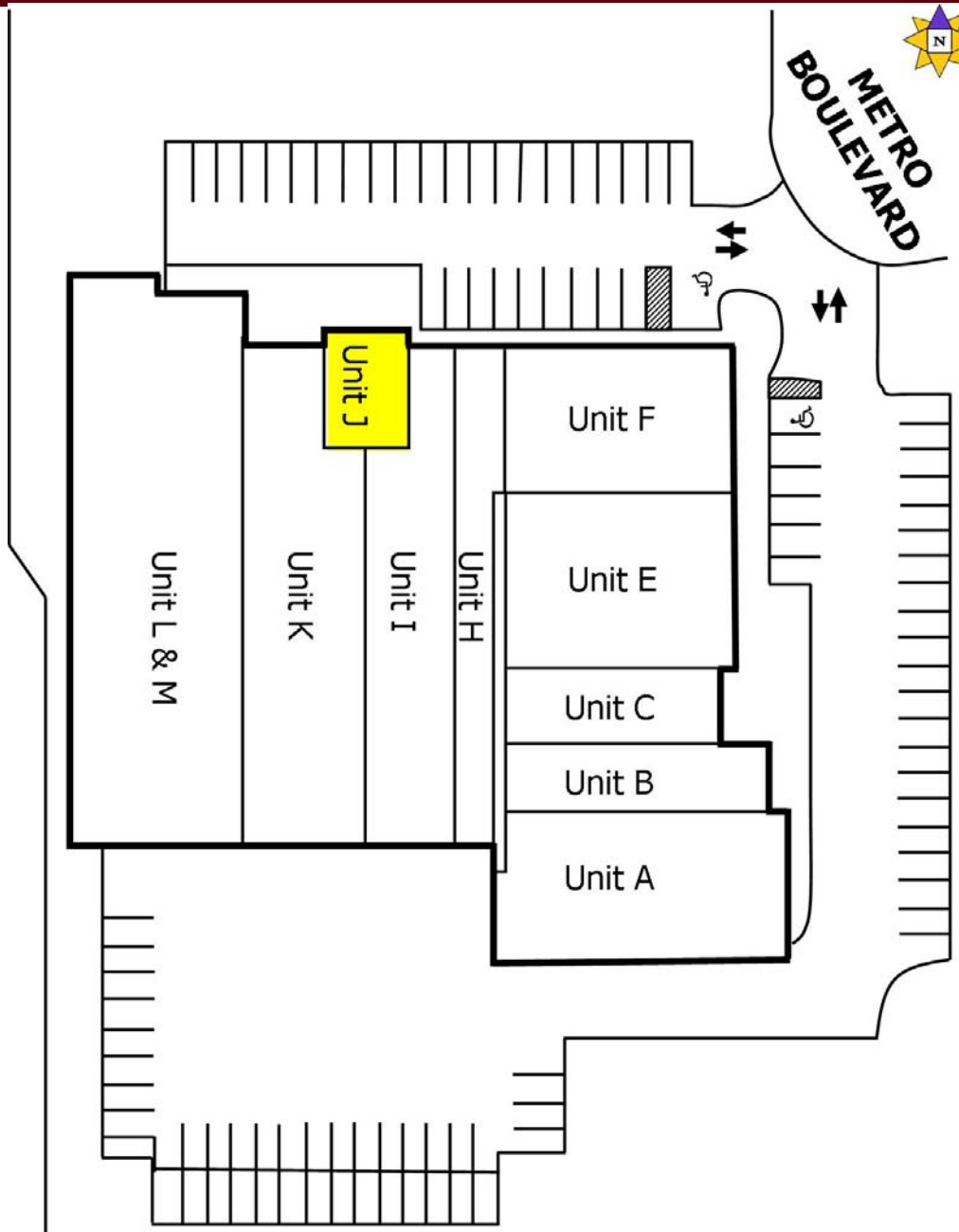

HUTKIN DEVELOPMENT COMPANY  
10829 Olive Boulevard  
Suite 200  
St. Louis, MO 63141

Telephone 314.872.9140  
FAX 314.872.9001

Visit our website:  
[www.hutkin.com](http://www.hutkin.com)

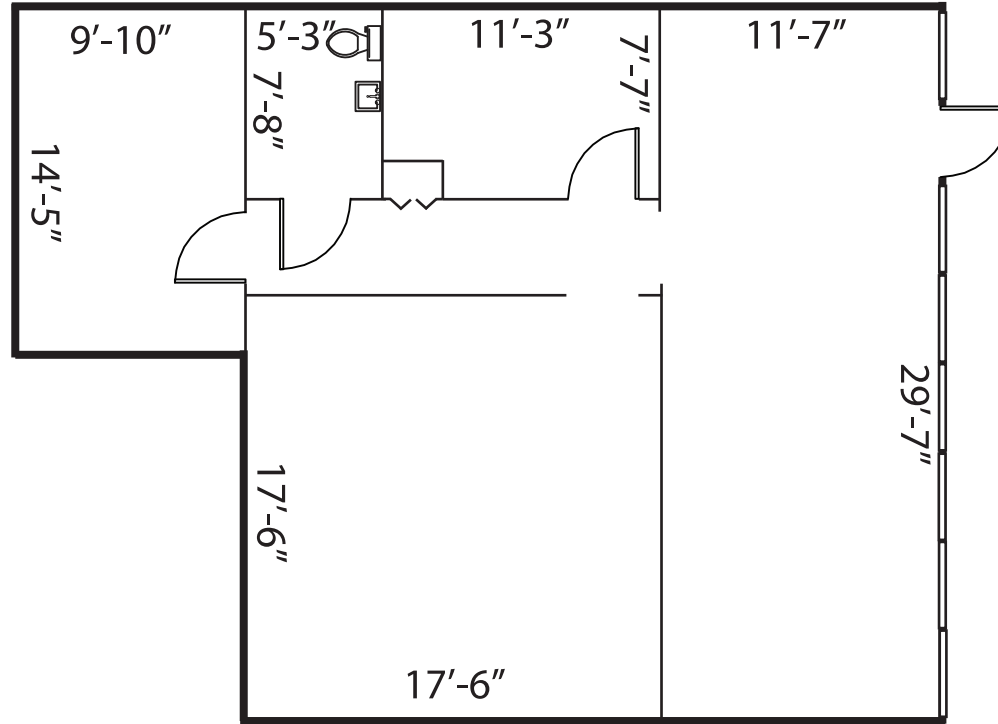

---

2505 METRO BLVD, UNIT J

1,080 SF

SCALE: NOT TO SCALE

---



**HUTKIN DEVELOPMENT COMPANY**

10829 Olive Boulevard, Suite 200

St. Louis, MO 63141

T: 314-872-9140 F: 314-872-9001